

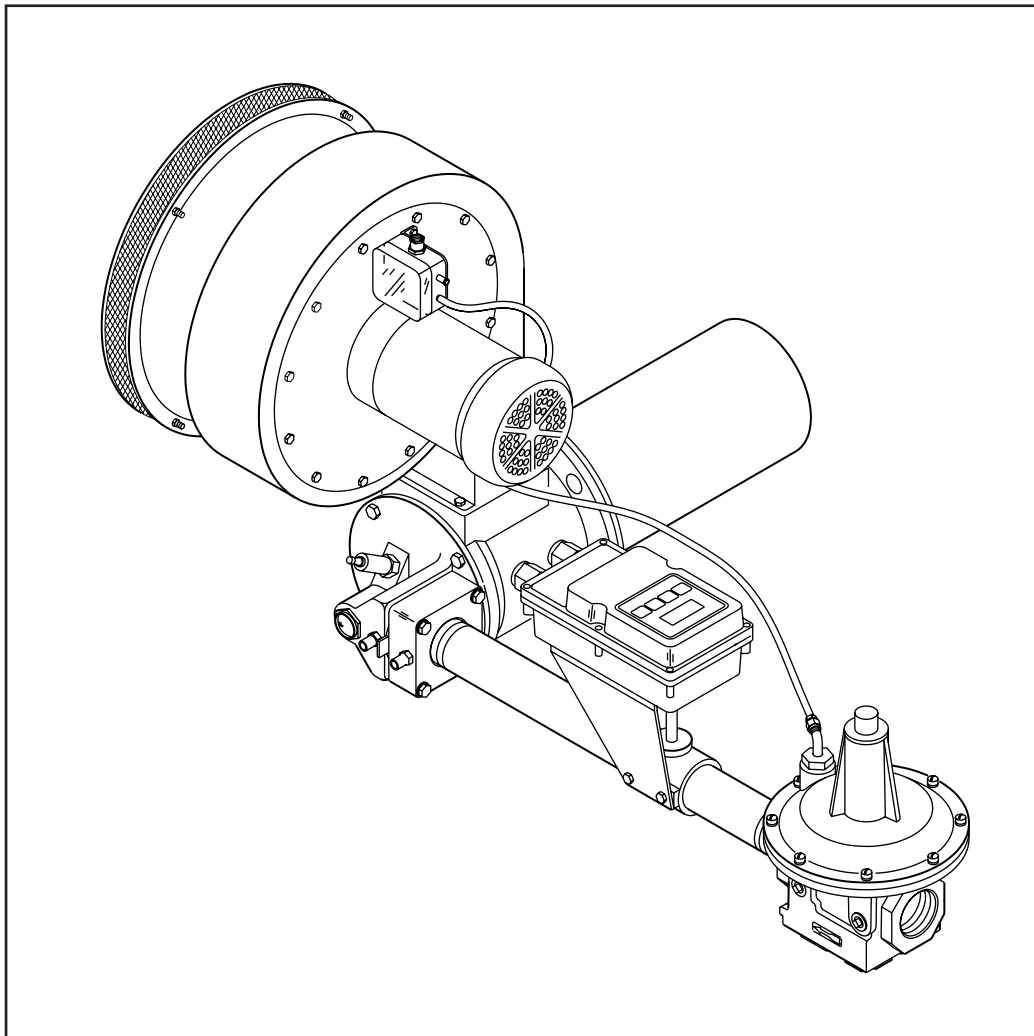

ThermAir Burners

TA Series
version 1



COPYRIGHT

Copyright 1998 by Eclipse Combustion, Inc. All rights reserved worldwide. This publication is protected by federal regulation and shall not be copied, distributed, transmitted, transcribed or translated into any human or computer language, in any form or by any means, to any third parties, without the express written consent of Eclipse Combustion, Inc., Rockford, Illinois, U.S.A.

We reserve the right to change the construction and/or configuration of our products at any time without being obliged to adjust earlier supplies accordingly.

DISCLAIMER NOTICE

The material in this manual is believed adequate for the intended use of the product. If the product, or its individual modules or procedures, are used for purposes other than those specified herein, confirmation of their validity and suitability must be obtained. Eclipse Combustion, Inc. warrants that the material itself does not infringe any United States patents. No further warranty is expressed or implied.

We have made every effort to make this manual as accurate and complete as possible. Should you find errors or omissions, please bring them to our attention so that we may correct them. In this way we hope to improve our product documentation for the benefit of our customers. Please send your corrections and comments to our Documentation Manager.

LIABILITY AND WARRANTY

It must be understood that Eclipse Combustion's liability for its products, whether due to breach of warranty, negligence, strict liability, or otherwise, is limited to the furnishing of such replacement parts and Eclipse Combustion will not be liable for any other injury, loss, damage or expenses, whether direct or consequential, including but not limited to loss of use, income of or damage to material arising in connection with the sale, installation, use of, inability to use or the repair or replacement of Eclipse Combustion's products.

Any operation expressly prohibited in this Guide, any adjustment, or assembly procedures not recommended or authorized in these instructions shall void the warranty.



About this manual

AUDIENCE

This manual has been written for people who are already familiar with all aspects of a nozzle-mix burner and its add-on components, also referred to as “the burner system.”

These aspects are:

- installation
- use
- maintenance.

The audience is expected to have had experience with this kind of equipment.

THERMAIR DOCUMENTS

Installation Guide No. 114

- This document

ThermAir Data Sheets, Series 114

- Available for individual TA models
- Required to complete design & selection

Design Guide No. 114

Used with Data Sheet to design burner system

ThermAir Price List No. 114

Used to order burners

RELATED DOCUMENTS

- EFE 825 (Combustion Engineering Guide)
- Eclipse Bulletins and Info Guides: 710, 732, 742, 760, 818, 832, 852, 854, 856, 610, 620, 630, 826, 820, 930, I-354.

Purpose

The purpose of this manual is to ensure the installation of a safe, effective, and trouble-free combustion system is carried out.

DOCUMENT CONVENTIONS

There are several special symbols in this document. You must know their meaning and importance.

The explanation of these symbols follows below. Please read it thoroughly.



Danger:

Indicates hazards or unsafe practices which WILL result in severe personal injury or even death.

Only qualified and well trained personnel are allowed to carry out these instructions or procedures.

Act with great care and follow the instructions.



Warning:

Indicates hazards or unsafe practices which could result in severe personal injury or damage.

Act with great care and follow the instructions.



Caution:

*Indicates hazards or unsafe practices which could result in damage to the machine or minor personal injury.
Act carefully.*



Note:

Indicates an important part of the text. Read thoroughly.

HOW TO GET HELP

If you need help, you can contact your local Eclipse representative. A complete listing of Eclipse representatives world wide can be found at www.eclipsenet.com.

You can also contact Eclipse at:

1665 Elmwood Rd.
Rockford, IL 61103
815-877-3031



Table of contents

	About this manual	3
	Audience	3
	ThermAir Documents	3
	Related Documents	3
	Document Conventions	4
	How to Get Help	4
	Table of Contents	5
1	Introduction	7
	Product Description	7
2	Safety	9
	Capabilities	10
	Operator Training	10
	Replacement Parts	10
3	Installation	11
	Handling and Storage	11
	Approvals of Components	11
	Electrical Wiring	12
	Where to get standards	12
	Pre-installation Checklist	13
	Burner	13
	Gas Piping	14
	Installing the flame sensor	15
	Check List After Installation	15
	Prepare for adjustment	16
4	Adjustment, Start & Stop	17
	Introduction	17
	System I	
	Burner adjustment with a ratio regulator	17
	Step 1 Reset the system	17
	Step 2 Verify Air flow	18
	Step 3a Ignite the burner (Option 1)	18
	Step 3b Ignite the burner (Option 2)	19
	Step 4 Set high fire gas	20
	Step 5 Set low fire gas	21
	Step 6 Verify gas settings	21

4	Adjustment, Start & Stop (Cont.)	21
	System 2	
	Burner adjustment without a ratio regulator	21
	Step 1 Reset the system	22
	Step 2 Verify the system	22
	Step 3a Ignite the burner (Option 1).....	22
	Step 3b Ignite the burner (Option 2)	23
	Step 4 Set high fire gas	24
	Step 5 Set low fire gas.....	24
	Step 6 Verify gas settings	24
5	Maintenance & Troubleshooting	25
	Maintenance	25
	Monthly Checklist	25
	Yearly Checklist	26
	Troubleshooting Procedures	27
	Appendix	30
	Conversion Factors	30
	Key to System Schematics	31
	Parts Drawing	32
	Parts List	33
	Parts List continued	34

Introduction

1

PRODUCT DESCRIPTION

The ThermAir burner (TA Series) is a nozzle-mix burner with a packaged combustion air blower that is designed to fire with fixed combustion air over a wide gas turndown range. An integral gas orifice is provided to ease burner setup. The burner is designed to facilitate:

- fixed air operation
- direct spark ignition
- simple gas control
- multiple fuel capability

The burner is suitable for direct and indirect air heating for a wide range of applications on industrial furnaces and ovens.

Figure 1.1 **ThermAir Burner**

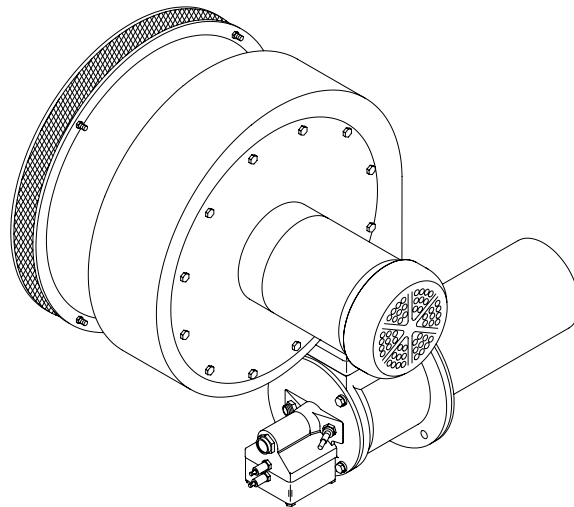

Blank page.



2

INTRODUCTION

SAFETY

This section is provided as a guide for the safe operation of the ThermAir burner system. All involved personnel should read this section carefully before operating this system.



Danger:

The ThermAir burners, described herein, are designed to mix fuel with air and burn the resulting mixture. All fuel burning devices are capable of producing fires and explosions if improperly applied, installed, adjusted, controlled, or maintained.

Do not bypass any safety feature; fire or explosion could result.

Never try to light a burner if it shows signs of damage or malfunction.



Warning:

The burner might have HOT surfaces. Always wear protective clothing when approaching the burner.



Note:

This manual provides information in the use of these burners for their specific design purpose. Do not deviate from any instructions or application limits described herein without written advice from Eclipse Combustion.

Read the entire manual before attempting to start this system. If you do not understand any part of the information contained in this manual, contact your local Eclipse representative or Eclipse Combustion before continuing.

CAPABILITIES

Only qualified personnel, with good mechanical aptitude and experience on combustion equipment, should adjust, maintain, or troubleshoot any mechanical or electrical part of this system.

OPERATOR TRAINING

The best safety precaution is an alert and trained operator. Train new operators thoroughly and have them demonstrate an adequate understanding of the equipment and its operation. A regular retraining schedule should be administered to ensure operators maintain a high degree of proficiency.

REPLACEMENT PARTS

Order replacement parts from Eclipse Combustion only. All Eclipse Combustion approved, customer supplied valves or switches should carry UL, FM, CSA, CGA, and/or CE approval, where applicable.

Installation

3

INTRODUCTION

HANDLING AND STORAGE

APPROVALS OF COMPONENTS

Limit Controls and Safety Equipment

In this section you will find important notices about safe operation of the burner:

Handling:

1. Make sure that the components are clean and free of damage.
2. Protect the components from weather, damage, dirt and moisture.
 - Transport in original shipping container
 - Do not drop
3. Protect the components from excessive temperatures and humidity.
4. Use appropriate support equipment, i.e. harnesses, straps, chains etc. when lifting burner components.

Storage:

1. Make sure that the area is clean.
2. Store the components in a cool, clean, dry room.
3. After you have made sure everything is present and in good condition, keep the components in the original package as long as possible.

All limit controls and safety equipment must comply with the current following standards:

- NFPA Standard 86
- NFPA Standard 86C
- UL
- FM
- CGA
- EN 746-2
- all applicable local codes and/or standards.

Electrical wiring

All electrical wiring must comply with one of these standards:

- NFPA Standard 70
- ANSI-C11981
- EN 746-2
- the electrical wiring must be acceptable to the local authority having jurisdiction

Gas Piping

All gas piping must comply with one of these standards:

- NFPA Standard 70
- ANSI Z223
- EN 746-2
- the gas piping must be acceptable to the local authority having jurisdiction

Where to get standards

The NFPA Standards are available from:
National Fire Protection Agency
Batterymarch Park
Quincy, MA 02269

The ANSI Standards are available from:
American National Standard Institute
1430 Broadway
New York, NY 10018

The UL Standards are available from:
333 Pfingsten Road
Northbrook, IL 60062

The FM Standards are available from:
1151 Boston-Providence Turnpike
P.O. Box 9102
Norwood, MA 02062

Information on the EN standards, and where to get the standards is available from:

Comité Européen de Normalisation
Strassartstraat 36
B-1050 Brussels
Phone: +32-25196811
Fax: +32-25196819

Comité Européen de Normalisation Electronique
Strassartstraat 36
B-1050 Brussels
Phone: +32-25196871
Fax: +32-25196919

PRE-INSTALLATION CHECKLIST

BURNER

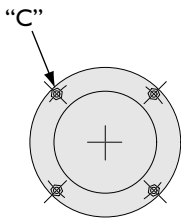
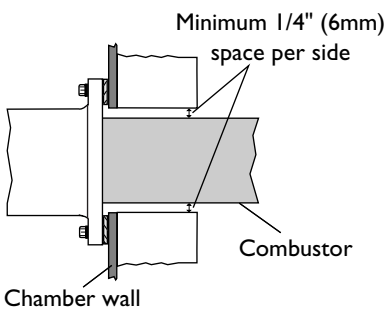

Air Supply

Provide an opening in the burner room of at least one square inch per 4000 BTU/hr (6 cm² per 1 kW) to supply the burner intake with fresh, outdoor, combustion air.

If there are corrosive fumes or materials in the surrounding air, find an uncontaminated source to supply air to the burner.

Exhaust

Do not allow exhaust gases to accumulate in the work area. Provide a means for exhausting these gases from the building.

Access

Install the burner so it may be easily accessed for inspection and maintenance.

Environment

Be sure the burner operating environment matches the original operating specifications. Check the following items:

- voltage, frequency, and stability of electrical power
- fuel type and fuel supply pressure
- adequate fresh, clean, combustion air
- humidity, altitude, and temperature of the supply air
- presence of damaging corrosive gases in the air
- prevent direct exposure to water.

Chamber Opening

Provide an opening in the chamber wall at least 1/2" (12mm) larger in diameter than the outside diameter of the combustor.

Provide an accessible pressure tap on the chamber wall to measure the pressure inside the firing chamber. The pressure tap should be located near the burner.

Mounting Pattern

Attach four mounting bolts to the chamber wall. Position these bolts to match the clearance holes (C) on the burner mounting flange. Refer to the appropriate ThermAir data sheet.

INSTALLATION

(CONTINUED)

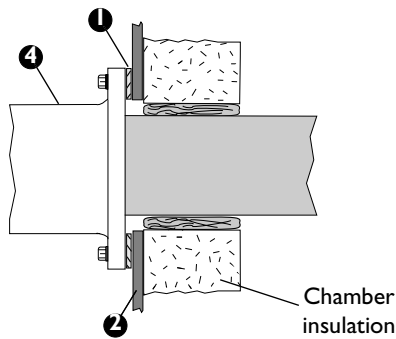

GAS PIPING

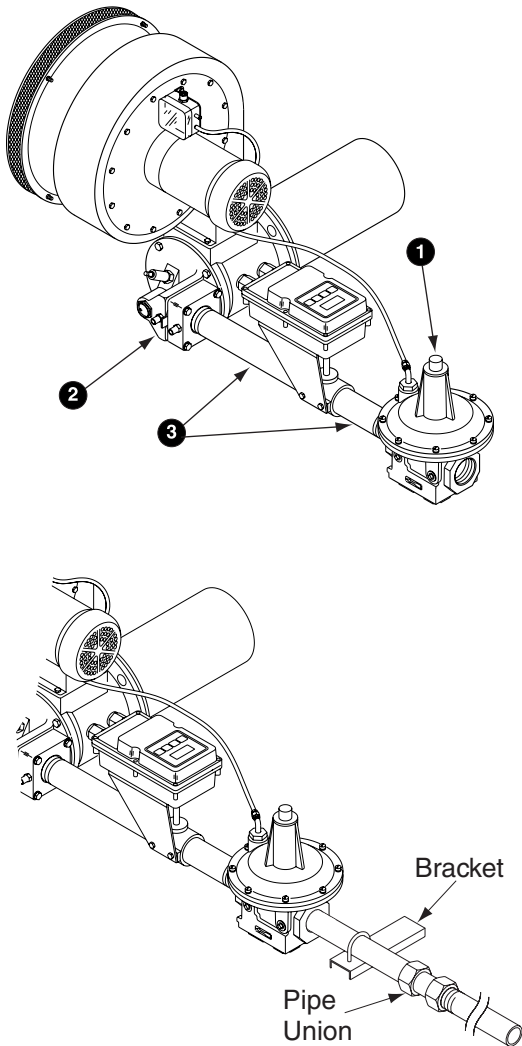

Chamber Wall

Make sure the chamber wall ② is strong enough to support the weight of the burner ④. If necessary, reinforce the mounting area.

Burner Mounting

Mount burner to chamber wall using four (4) customer supplied nuts and lock washers.

1. Make sure that you install the burner mounting gasket, item ①, between the burner mounting flange and the chamber wall.
2. Make sure that the gasket does not leak.

Insulate the Firing Tube

To insure that radiated heat doesn't reach the exterior of the chamber, insulate the combustion tube over the length contained within the chamber wall, filling any clearance completely. If the firing tube extends beyond the chamber wall thickness, **do not** insulate the exposed end of the tube.

Burner Piping

The burner is factory assembled and shipped as ordered.

Note:

If it is necessary to redirect piping, be sure the:

- ratio regulator spring column ① is pointing up.
- arrow on the ratio regulator points in the direction of gas flow.
- integral fuel orifice and o-rings ② are re-installed.
- same straight runs of pipe ③ remains between the ratio regulator and the burner.

Supply Piping

Inlet pressure to the ratio regulator (if supplied) should be at least 15" w.c. (37.5 mbar). It should not exceed the maximum pressure rating of the ratio regulator.

- Locate the valve train close to the burner. The gas must reach the burner during the fixed trial for ignition.
- Sufficiently size shut off valves in the valve train.
- Make sure piping is large enough.
- Minimize piping elbows.

Pipe Connections

- Installation of a pipe union in the gas line is recommended to simplify burner removal.
- Use of flexible pipe is optional.



Note:

Flexible pipe causes higher pressure drops than standard pipe. Consider this when sizing your gas lines.

Installing the flame sensor

CHECK LIST AFTER INSTALLATION

Piping Support

Use brackets or hangers to support the gas piping. If you have questions, consult your local gas company.

Control Motor

Install a control motor to modulate the gas control valve if not previously installed on the burner.

There are two different types of flame sensors:

U.V. scanner:

Each ThermAir burner is capable of U.V. flame monitoring. The burner will not come equipped with a U.V. scanner. A ½" NPT connection is provided on each ThermAir burner for the connection of a U.V. scanner.

For detailed information on how to install and connect an Eclipse U.V. scanner, refer to:

- straight U.V. scanner; Bulletin / Info Guide 854
- 90° U.V. scanner; Bulletin / Info Guide 852
- self-check U.V. scanner; Bulletin / Info Guide 856.

Flame rod:

If the flame rod option was selected when the burner was ordered, the burner will be delivered with the flame rod already installed on the burner.



Note:

Only specific burner sizes are capable of using a flame rod. These models are TA015, 025, 040, 075, and 100.

For detailed information on how to install and connect a flame rod, refer to:

- Bulletin / Info Guide 832.

To verify the system was properly installed, perform the following checks:

1. Be sure there are no leaks in the gas lines.
2. Be sure all the components contained in the flame monitoring and control system are properly installed. This includes verifying that:
 - all the switches are installed in the correct locations.
 - all wiring, pressure, and impulse lines are properly connected.
3. Be sure all components of the spark ignition system are installed and functioning properly.
4. Be sure the blower rotates in the proper direction. If the rotation is incorrect, have a qualified electrician rewire the blower to rotate in the proper direction.
5. Be sure all valves are installed in the proper location and correctly oriented relative to the flow direction.

PREPARE FOR ADJUSTMENT

After installation of the burner system components is complete, the following steps should be followed in order to prepare for adjustment:

1. Set the air flow switch so that it drops out at 20% below the maximum pressure of the combustion air blower.
2. Set the low gas pressure switch at 20% below the gas pressure measured at the inlet to the main gas valve train.
3. Set the high gas pressure switch at 20% above the gas pressure measured at the inlet to the main gas valve train.
4. Close all manual valves feeding the burner.
5. Try to ignite the burner before the purge and other timers have finished their cycles. Make sure that the flame monitoring system indicates a flame failure.
6. Trip out the pressure switches and other limit interlocks. Make sure that the main gas valve train closes.



Danger:

If simulated limits or simulated flame failures do not shut down the fuel system within the required failure response time, immediately correct the problem before proceeding.

Adjustment, Start & Stop

4

INTRODUCTION

In this chapter you will find instructions on how to start and stop a burner. The chapter begins with general instructions that are useful for adjustment.



Danger:

The ThermAir burners, described herein, are designed to mix fuel with air and burn the resulting mixture. All fuel burning devices are capable of producing fires and explosions if improperly applied, installed, adjusted, controlled, or maintained.

Do not bypass any safety feature; fire or explosion could result.

Never try to light a burner if it shows signs of damage or malfunction.

Adjustment

There are two separate system adjustment procedures:

- **System 1**

Adjust a ThermAir burner with a ratio-regulator

- **System 2**

Adjust a ThermAir burner without a ratio-regulator

SYSTEM 1 BURNER ADJUSTMENT With a Ratio-Regulator

If you are adjusting a ThermAir burner equipped with a ratio-regulator for the first time, you must follow these steps:

1. Reset the system
2. Verify air flow
3. Ignite the burner
4. Set high fire gas
5. Set low fire gas
6. Verify gas settings
7. Stop Procedure

Step 1: Reset the system

1. Close these valves
 - the automatic gas valves
 - the manual gas cocks
2. Start the combustion air blower

Step 2: Verify air flow

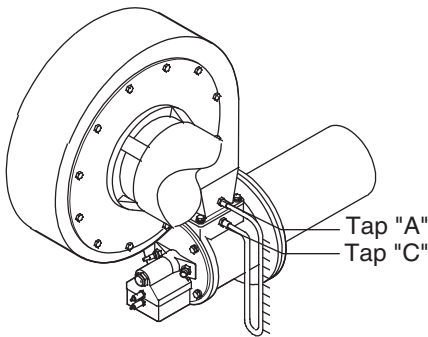
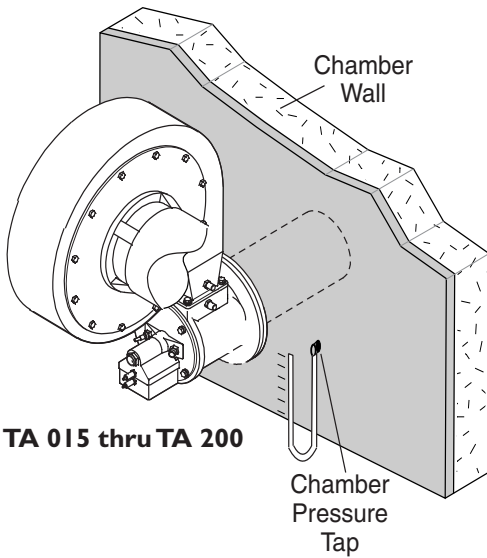

Step 3a: Ignite the burner (Option 1: Burner not equipped with bypass start gas)

TA 015, 025, 040, 075, 100, 200

1. Make sure that the pressure tap located on the chamber is open.
2. Connect the manometer to the chamber pressure tap.
3. Measure the chamber air pressure.
4. Determine actual air flow from the burner specific Data Sheet (ref.: Air flow vs. Chamber Pressure Chart) for the burner being setup.
5. Remove the manometer.
6. Close the pressure tap.

TA 300, 400, 500

1. Make sure that pressure taps A and C are open.
2. Connect the manometer to taps A and C.
3. Measure the air differential pressure.
4. Determine actual air flow from the burner specific Data Sheet (ref.: Air flow vs. Air Orifice ΔP Chart) for the burner being setup.
5. Remove the manometer.
6. Close the pressure taps



Note:

A pressure tap is open when the screw inside the tap is unscrewed approximately half a turn.



Note:

Chamber pressure will directly influence air flow from the blower. Air flows should be rechecked once the process reaches its operating temperature and pressure. An oxygen analyzer may be used to confirm air flow rates once the system is operating.

There are two separate ignition procedures which depend upon whether or not bypass start gas is installed on the burner. Each procedure is unique and both are outlined below.



Warning:

This procedure assumes that a flame monitoring control system is installed and is serviceable. It also assumes that normal low fire start is being used.

If low fire gas is too low to be used for ignition consider increasing low fire or providing bypass start gas. Refer to the section 3b on page 19.

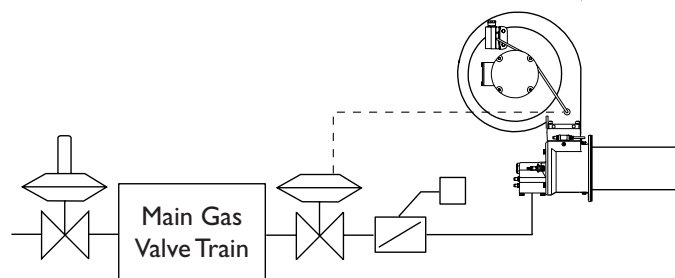

**Step 3b: Ignite the burner
(Option 2: Burner equipped
with bypass start gas)**

1. Drive the gas control valve to low fire.



Note:

All ThermAir burners are limited to ignition at inputs below 40% of maximum unless the control circuit on page 15 of Design Guide 114 is followed.

2. Make sure the combustion air blower is running.
3. Verify that the adjusting screw on the ratio-regulator is six full (360°) turns down from the top.
4. Open all manual gas valves feeding the burner.
5. Initiate the ignition sequence through the flame monitoring control system.
6. Verify that the burner has ignited.

If the burner does not ignite:

- a) Try to ignite again to purge the air out of the gas piping.
- b) If the burner does not ignite after one or two additional ignition attempts, see the Trouble shooting Guide contained in the Maintenance & Troubleshooting section of this guide.



Warning:

This procedure assumes that a flame monitoring control system is installed and is serviceable. It also assumes that a normal, low fire start is being used.

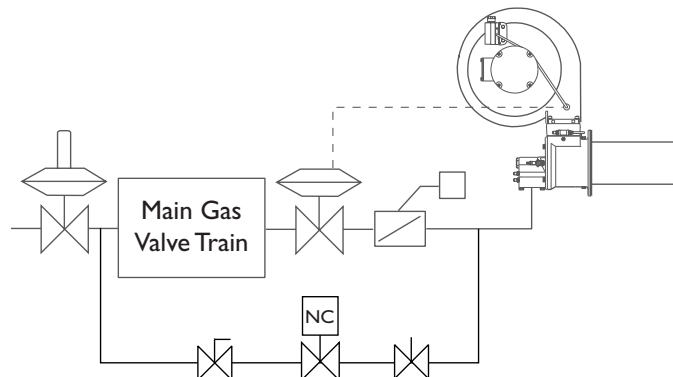

1. Drive the gas control valve to low fire.
2. Make sure the combustion air blower is running.
3. Verify that the adjusting screw on the ratio-regulator is six full (360°) turns down from the top.
4. Open the flow adjusting valve in the bypass gas line.
5. Open the manual gas valve in the bypass gas line.
6. Initiate the ignition sequence through the flame monitoring control system.
7. Verify that the burner has ignited.

If the burner does not ignite:

- a) Try to ignite again to purge the air out of the gas piping.
- b) If the burner does not ignite after one or two additional ignition attempts, see the Trouble shooting Guide contained in the Maintenance & Troubleshooting section of this guide.

Step 4: Set high fire gas

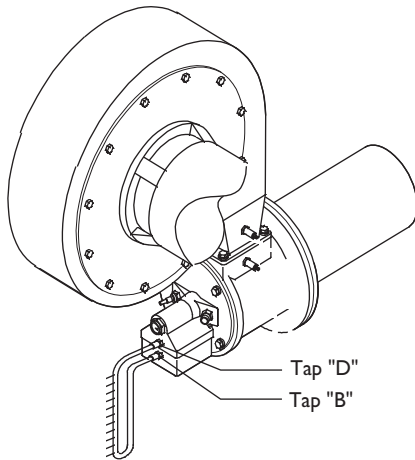

If the burner has ignited:

- a) Adjust the bypass flow adjusting valve such that the burner is able to maintain a stable flame and an adequate flame signal.
- b) Open all remaining manual gas valves feeding the burner.

1. If the burner has and is ignited, drive the main gas control valve to high fire (full open).
2. Verify air flow with the burner firing, repeat Step 2 "Verify air flow".
3. Make sure that pressure taps B and D are open.
4. Connect the manometer to taps B and D.
5. Measure the gas differential pressure.
6. Use the gas curve from the appropriate ThermAir Data Sheet for the gas being used to find the differential gas pressure needed at high fire.



Note:

Select the appropriate gas orifice differential pressure based upon the desired amount of excess air in the burner.

7. Readjust the control valve linkage to achieve the desired high fire gas flow.



Note:

The ThermAir gas orifice is sized to limit high fire gas flow to approximately 15% excess air with a packaged burner assembly purchased with a ratio-regulator and gas control valve.

8. Once the chamber conditions stabilize, (i.e. pressure and temperature), repeat items 2 through 7.
9. Check the gas pressure at the inlet to the ratio regulator. This should be at least 15" w.c. (37.5 mbar) It should not exceed the maximum pressure rating of the ratio regulator.



Warning:

Insufficient gas inlet pressure may cause the ratio regulator to remain fully open if there is a loss of air flow to the burner. This can cause excess fuel operation and the possible accumulation of unburned fuel in the chamber.

In extreme cases, this may cause explosions or fires.

Step 5: Set low fire gas

Step 6: Verify gas settings

SYSTEM 2 BURNER ADJUSTMENT Without a Ratio-Regulator

Step 1: Reset the system

10. Remove the manometer.

11. Close the pressure taps.

1. Drive the main gas control valve to low fire.

2. Adjust the control valve linkage to provide the desired low fire gas flow.



Note:

It is very difficult to measure the very low gas pressures experienced at low fire, and it may be necessary to rely on visual inspection of the flame. This is especially true when gas turndowns in excess of 10 to 1 are being used. The main intent is to provide a stable flame with good flame signal that will not cause the chamber temperature to overshoot.

Make sure that all settings are still the same after cycling the system several times between high and low fire.

You must provide a constant pressure to the burner to insure proper burner operation. If you are not using a burner equipped with a ratio-regulator, you must provide a service pressure regulator in order to maintain a constant inlet pressure to the burner.

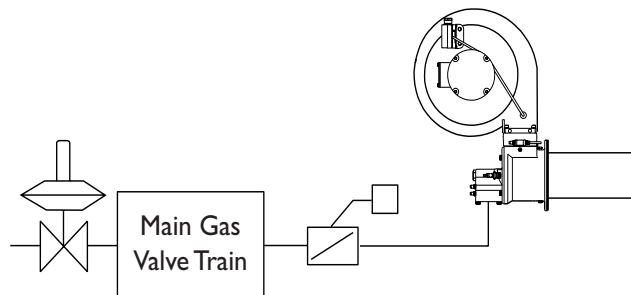

If you are adjusting a ThermAir burner equipped without a ratio-regulator for the first time, you must follow these steps:

1. Reset the system
2. Verify air flow
3. Ignite the burner
4. Set high fire gas
5. Set low fire gas
6. Verify gas settings

1. Close these valves

- the automatic gas valves
- the manual gas cocks

2. Start the combustion air blower

Step 2: Verify the system

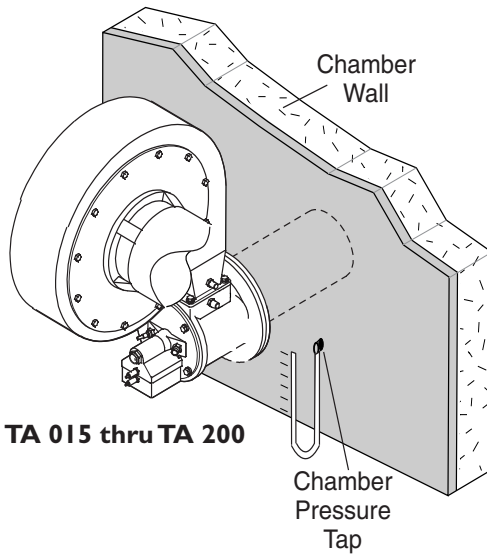

TA 015 thru TA 200

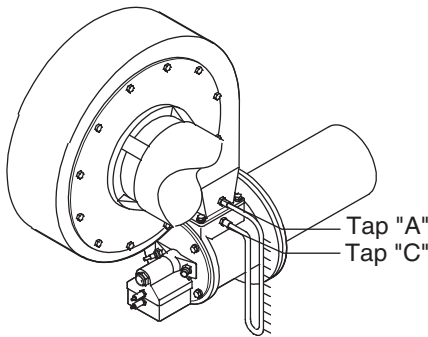

TA 300 thru TA 500

Step 3a: Ignite the burner (Option 1: Burner not equipped with bypass start gas.) Ref. illustration page 21.

TA 015, 025, 040, 075, 100, 200

1. Make sure that the pressure tap located on the chamber is open.
2. Connect the manometer to the chamber pressure tap.
3. Measure the chamber air pressure.
4. Determine actual air flow from the burner specific Data Sheet (ref.:Air flow vs. Chamber Pressure Chart) for the burner being setup.
5. Remove the manometer.
6. Close the pressure tap.

TA 300, 400, 500

1. Make sure that pressure taps A and C are open.
2. Connect the manometer to taps A and C.
3. Measure the air differential pressure.
4. Determine actual air flow from the burner specific Data Sheet (ref.:Air flow vs. Air Orifice ΔP Chart) for the burner being setup.
5. Remove the manometer.
6. Close the pressure taps



Note:

A pressure tap is open when the screw inside the tap is



Note:

Chamber pressure will directly influence air flow from the blower. Air flows should be rechecked once the process reaches its operating temperature and pressure. An oxygen analyzer may be used to confirm air flow rates once the system is

There are two separate ignition procedures which depend upon whether or not bypass start gas is installed on the burner. Each procedure is unique and both are outlined below.



Warning:

This procedure assumes that a flame monitoring control system is installed and is serviceable. It also assumes that normal low fire start is being used.

If low fire gas is too low to be used for ignition consider increasing low fire or providing bypass

1. Drive the gas control valve to low fire.

Note:

All ThermAir burners are limited to ignition at inputs below 40% of maximum unless the control circuit on page 15 of Design Guide 114 is followed

**Step 3b: Ignite the burner
(Option 2: Burner equipped
with bypass start gas.)**

2. Make sure the combustion air blower is running.
3. Open all manual gas valves feeding the burner.
4. Initiate the ignition sequence through the flame monitoring control system.
5. Verify that the burner has ignited.

If the burner does not ignite:

- a) Try to ignite again to purge the air out of the gas piping.
- b) If the burner does not ignite after one or two additional ignition attempts, see the Trouble shooting Guide contained in the Maintenance & Troubleshooting section of this guide.



Warning:

This procedure assumes that a flame monitoring control system is installed and is serviceable. It also assumes that normal low-fire start is being used.

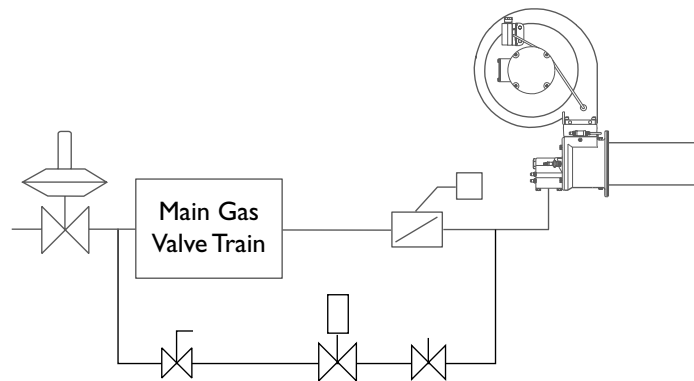

1. Drive the gas control valve to low fire.
2. Make sure the combustion air blower is running.
3. Verify that the adjusting screw on the ratio-regulator is six full (360°) turns down from the top.
4. Open the flow adjusting valve in the bypass gas line.
5. Open the manual gas valve in the bypass gas line.
6. Initiate the ignition sequence through the flame monitoring control system.
7. Verify that the burner has ignited.

If the burner does not ignite:

- a) Try to ignite again to purge the air out of the gas piping.
- b) If the burner does not ignite after one or two additional ignition attempts, see the Trouble shooting Guide contained in the Maintenance & Troubleshooting section of this guide.

If the burner has ignited:

- a) Adjust the bypass flow adjusting valve such that the burner is able to maintain a stable flame and an adequate flame signal.
- b) Open all remaining manual gas valves feeding the burner.

Step 4: Set high fire gas

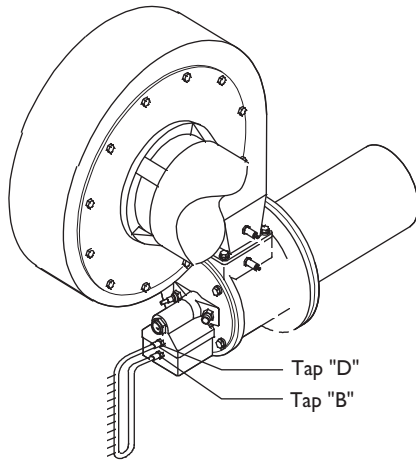

1. If the burner has and is ignited, set the main gas pressure regulator for 7" w.c. outlet pressure.
2. Drive the main gas control valve to high fire (full open).
3. Verify air flow with the burner firing, repeat Step 2 "Verify air flow".
4. Make sure that pressure taps B and D are open.
5. Connect the manometer to taps B and D.
6. Measure the gas differential pressure.
7. Use the gas curve from the appropriate ThermAir Data Sheet for the gas being used to find the differential gas pressure needed at high fire.



Note:

Select the appropriate gas orifice differential pressure based upon the desired amount of excess air in the burner.

8. Adjust the adjusting screw on the main gas pressure regulator to achieve the desired gas flow.
9. Once the chamber conditions stabilize, (i.e. pressure and temperature), repeat Steps 3 through 8.
10. Remove the manometer.
11. Close the pressure taps.

Step 5: Set low fire gas

1. Drive the main gas control valve to low fire.
2. Adjust the control valve linkage to provide the desired low fire gas flow.



Note:

It is very difficult to measure the very low gas pressures experienced at low fire, and it may be necessary to rely on visual inspection of the flame. This is especially true when gas turndowns in excess of 10 to 1 are being used. The main intent is to provide a stable flame with good flame signal that will not cause the chamber temperature to overshoot.

Step 6: Verify gas settings

Make sure that all settings are still the same after cycling the system several times between high and low fire.

Step 7: Stop Procedure



Caution:

Do not turn the combustion air blower off until the chamber temperature is below 250°F (121°C). This will prevent hot gases from back flowing into the burner and blower causing damage to the burner.

1. Stop the burner through the burner control system.
2. Run the combustion air blower until the chamber temperature drops below 250°F (121°C).
3. Shut off the combustion air blower.
4. Close all manual gas valves to the burner.

Maintenance & Troubleshooting

5

INTRODUCTION

This chapter is divided into two sections:

- Maintenance procedures
- Troubleshooting guide

Preventive maintenance is the key to a reliable, safe and efficient system. The core of any preventive maintenance system is a list of periodic tasks.

MAINTENANCE



Note:

These are guidelines only. The customer should make the final determination on maintenance intervals and tasks to be performed while considering the working environment.

Monthly Checklist

1. Inspect the flame sensing devices for good condition and cleanliness.
2. Check for proper air/gas pressures (Refer to the ThermAir Data Sheets, Series 114).
3. Test all the system alarms for proper response signals.
4. Check and clean igniter electrodes.
5. Check valve motors and control valves for free, smooth action and adjustment.
6. Check for the proper operation of ventilating equipment.
7. Test the interlock sequence on all safety equipment. Manually force each interlock to intentionally fail while at the same time noting if related equipment closes or stops as specified by the manufacturer. Test the flame safeguard by manually shutting off the gas to the burner.
8. Test the manual gas shut off cocks for proper operation.
9. Clean and/or replace the combustion air blower filter.
10. Inspect and clean the combustion air blower rotor.

Yearly Checklist

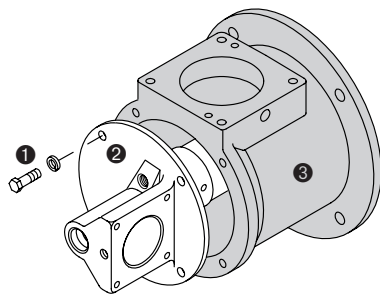

1. Leak test the safety shut-off valves for tightness of closure.
2. Test the pressure switch settings by checking the switch movements against pressure settings and comparing these with the actual impulse pressure.
3. Visually check igniter cable and connectors.
4. Remove, clean, and inspect all burners.
5. Be sure the following components are not damaged or distorted:
 - the burner nozzle.
 - the igniter.
 - the flame sensors.
 - the combustion tube.

The nozzle and combustion tube can be inspected without removing the burner from the chamber wall or entering the chamber. Perform the following:

- a. Shut the burner off and manually close the main gas shut off cocks.
- b. Allow the chamber temperature to cool down to 250°F (121°C).
- c. Disconnect the gas piping at a union or the gas inlet flange provided on the burner.
- d. Remove the four bolts ①.
- e. Remove the rear cover ② from the burner housing ③.
- f. To re-assemble, follow this sequence in the reverse order.

TROUBLESHOOTING PROCEDURES

PROBLEM	POSSIBLE CAUSE	SOLUTION
Start-up sequence runs but burner does not light.	No ignition: <ul style="list-style-type: none"> Attempting to ignite at inputs greater than 40%. 	Reduce start point gas flow. Verify control circuit.
	No ignition: <ul style="list-style-type: none"> Weak or non-existent spark. 	Verify ignition transformer is a 6,000 - 8,000 volt transformer. (Not half-wave)
	No ignition: <ul style="list-style-type: none"> There is no power to the ignition transformer. 	Restore the power to the ignition transformer.
	No ignition: <ul style="list-style-type: none"> Open circuit between the ignition transformer and the igniter. 	Repair or replace the wiring to the igniter.
	No ignition: <ul style="list-style-type: none"> The igniter needs cleaning. 	Clean the igniter.
	No ignition: <ul style="list-style-type: none"> The igniter is not correctly grounded to the burner. 	Clean the threads on the igniter and the burner. NOTE: Do not apply grease to the threads on the igniter.
	No ignition: <ul style="list-style-type: none"> Igniter insulator is broken. Igniter is grounding out. 	Inspect the igniter. Replace if broken.
	Not enough gas: <ul style="list-style-type: none"> The gas flow into the burner is too low. 	Check the start-up settings. Adjust low fire gas setting if necessary.
	Not enough gas: <ul style="list-style-type: none"> If equipped with ratio regulator, loading line may not be attached 	Reconnect loading line and verify loading pressure.
	Not enough gas: <ul style="list-style-type: none"> The bypass valve is not open far enough. 	Adjust bypass gas flow.
	Not enough gas: <ul style="list-style-type: none"> Start gas solenoid valve does not open. 	Check the solenoid valve coil for proper operation. Replace it if necessary.
	Not enough gas: <ul style="list-style-type: none"> Gas valve does not open. 	Check the wiring to the automatic gas shut-off valve. Check the output from the flame safeguard. Open manual gas cock.

PROBLEM	POSSIBLE CAUSE	SOLUTION
Start-up sequence runs but burner does not light. (continued)	No flame signal: <ul style="list-style-type: none"> • Broken flamerod • Dirty UV scanner lens 	Inspect and clean sensor Replace if necessary
	No flame signal: <ul style="list-style-type: none"> • Flamerod grounding out 	Verify that the flamerod is installed correctly and is the correct length.
	Too much gas: <ul style="list-style-type: none"> • Wrong or missing burner fuel orifice. 	Check ThermAir Data Sheets, Series 114 for fuel orifice and the given fuel.
The low fire flame is weak or unstable.	<ul style="list-style-type: none"> • Not enough gas flowing to the burner. 	Adjust the gas control valve to increase the gas flow.
	<ul style="list-style-type: none"> • Not enough air. 	Check for proper blower rotation. Check air filter for blockage.
The burner goes out when it cycles to high fire.	<ul style="list-style-type: none"> • Too much gas to the burner. 	Verify gas orifice size for your fuel (ref. Data Sheets 114). Verify chamber pressure for proper air flow effect. Check the start-up settings. Measure the gas pressures and adjust them where necessary. Check for valve train pressure loss.
	<ul style="list-style-type: none"> • Loading line to the ratio regulator (if installed) is leaking. 	Repair the leak in the loading line.
The burner is erratic and does not respond to adjustment.	Internal damage to the burner: <ul style="list-style-type: none"> • Some parts inside the burner are loose, dirty, or burned out. 	Contact your Eclipse representative or Eclipse Combustion for further information.
The burner is unstable or produces soot or smoke.	<ul style="list-style-type: none"> • The air/gas ratio is out of adjustment. 	Measure all the gas pressures and air pressures. Compare these pressures to the documented initial start-up settings and adjust them where necessary.
The burner cannot achieve full capacity.	<ul style="list-style-type: none"> • Air filter is blocked. (When equipped with Ratio Regulator) 	Clean or replace the air filter.
	<ul style="list-style-type: none"> • Gas pressure going into the burner is too low. 	Adjust the gas pressure.
	<ul style="list-style-type: none"> • Combustion chamber pressure is too high. 	Derate burner for positive pressure installations.

PROBLEM	POSSIBLE CAUSE	SOLUTION
Cannot initiate a start sequence.	<ul style="list-style-type: none"> Air pressure switch has not made contact. 	Check air pressure switch adjustment. Check air filter. Check blower rotation. Check outlet pressure from blower.
	<ul style="list-style-type: none"> High gas pressure switch has activated. Low gas pressure switch has activated. 	Check incoming gas pressure. Adjust gas pressure if necessary. Check pressure switch setting and operation.
	<ul style="list-style-type: none"> Malfunction of the flame safeguard system (e.g., shorted-out flame sensor or electrical noise in the sensor line). No power to the control unit. 	Have a qualified electrician troubleshoot and correct the problem.
	<ul style="list-style-type: none"> Main power is off. 	Be sure the main power to the system is switched to the “on” position.

Appendix

CONVERSION FACTORS

Metric to English.

From	To	Multiply By
cubic meter (m ³)	cubic foot (ft ³)	35.31
cubic meter/hour (m ³ /h)	cubic foot/hour (cfh)	35.31
degrees Celsius (°C)	degrees Fahrenheit (°F)	(°C × 1.8) + 32
kilogram (kg)	pound (lb)	2.205
kilowatt (kW)	BTU/hr	3414
meter (m)	foot (ft)	3.28
millibar (mbar)	inches water column ("w.c.)	0.401
millibar (mbar)	pounds/sq in (psi)	14.5 × 10 ⁻³
millimeter (mm)	inch (in)	3.94 × 10 ⁻²
MJ/m ³ (normal)	BTU/ft ³ (standard)	2.491 × 10 ⁻²

Metric to Metric.







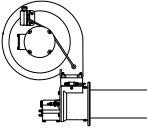

kiloPascals (kPa)	millibar (mbar)	10
meter (m)	millimeter (mm)	1000
millibar (mbar)	kiloPascals (kPa)	0.1
millimeter (mm)	meter (m)	0.001

English to Metric.

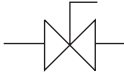
From	To	Multiply By
BTU/hr	kilowatt (kW)	0.293 × 10 ⁻³
cubic foot (ft ³)	cubic meter (m ³)	2.832 × 10 ⁻²
degrees Fahrenheit (°F)	degrees Celsius (°C)	(°F - 32) ÷ 1.8
foot (ft)	meter (m)	0.3048
inches (in)	millimeter (mm)	25.4
inches water column ("wc)	millibar (mbar)	2.49
pound (lb)	kilogram (kg)	0.454
pounds/sq in (psi)	millibar (mbar)	68.95
BTU/ft ³ (standard)	MJ/m ³ (normal)	40.14

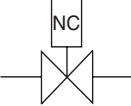
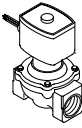
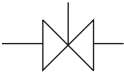
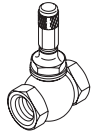
**KEY TO SYSTEM
SCHEMATICS**

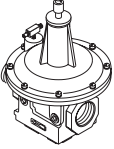
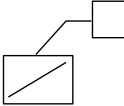
These are the symbols used in the schematics.

Symbol	Appearance	Name	Remarks	Bulletin/ Info Guide
		ThermAir		
		Main Gas Shutoff Valve Train	Eclipse Combustion, Inc. strongly endorses NFPA as a minimum	756
		Gas Cock	Gas cocks are used to manually shut off the gas supply on both sides of the main gas shut-off valve train.	710
		Solenoid Valve (normally closed)	Solenoid valves are used to automatically shut off the gas supply on a bypass gas system or on small capacity burners.	760
		Adjustable Limiting Orifice	Adjustable limiting orifices are used for fine adjustment of gas flow.	730
		Pressure Regulator	A pressure regulator reduces gas pressure to a stable, usable pressure.	684
		Ratio Regulator	The ratio regulator adjusts the gas flow in ratio with the air flow. It controls the outlet pressure equal to the impulse line pressure. The impulse line is connected between the top of the ratio regulator and the blower housing.	742
		Automatic Gas Control Valve	An automatic gas control valve adjusts gas flow to the burner based on control system requirements.	720
		Impulse Line		

ThermAir Parts Drawing

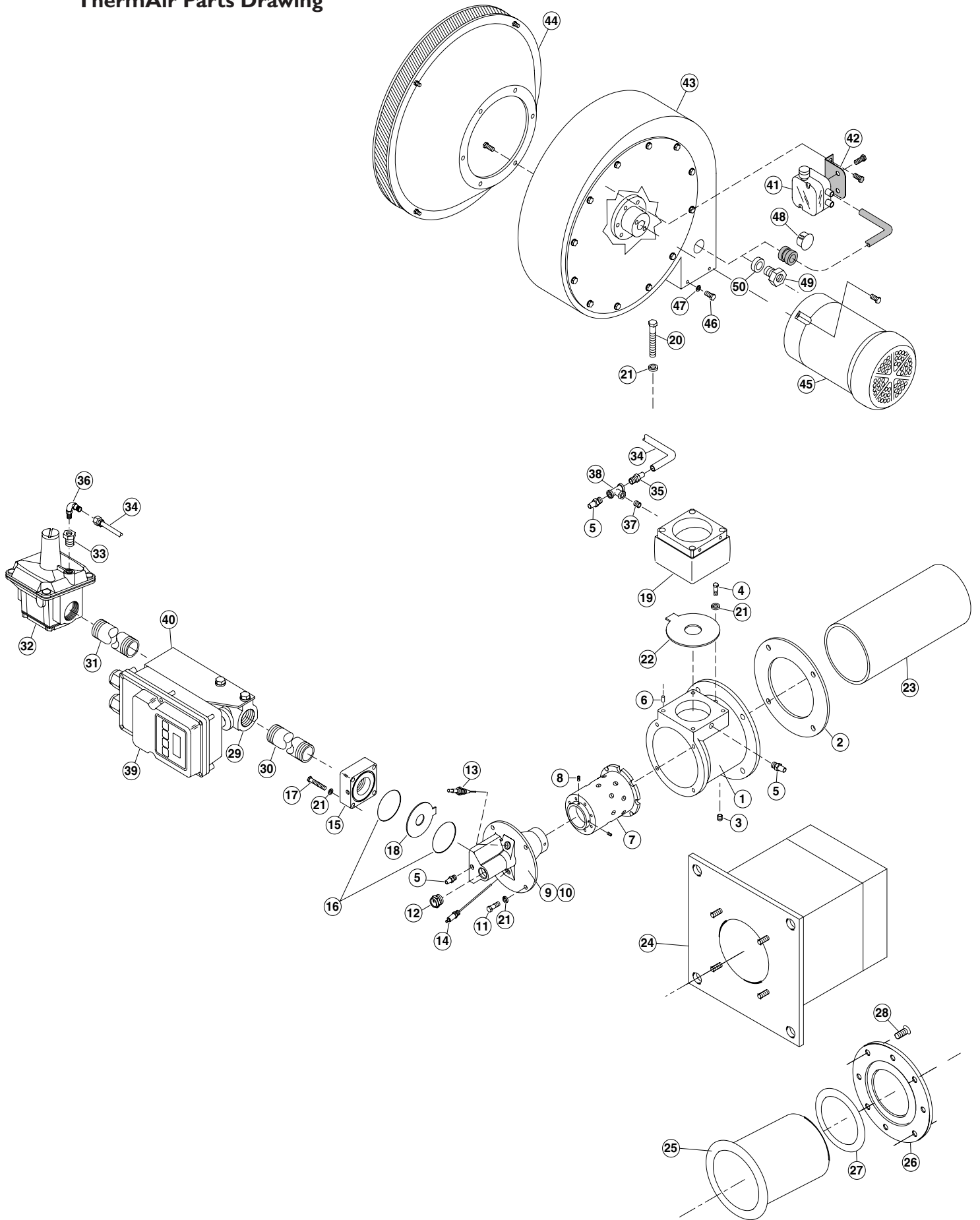

ThermAir Parts List

Pos.	Qty.	Description	TA015	TA025	TA040	TA075	TA100	TA200	TA300	TA400	TA500
1	1	Body,alloy tube	7118-1	7118-1	7118-1	7046-1	3994	3994	7036-1	7036-1	7111-1
1	1	Body,SiC	7118-2	7118-2	7118-2	7046-3	3994-1	3994-1	N/A	N/A	N/A
2	1	Gasket, mounting	17054	17054	17054	20422	14932	14932	10027	10027	20151
3	2	Plug,0.125"NPT	15398	15398	15398	16022	16022	16022	15398	15398	15398
4	2	Screw,body	16022	16022	16022	16022	16022	16022	N/A	N/A	N/A
5	4	Tap,pressure	13445	13445	13445	13445	13445	13445	13445	13445	13445
6	4	Insert,thread,M12xM8	N/A	N/A	N/A	N/A	N/A	N/A	N/A	N/A	20304
7	1	Nozzle	7033-1	7033-2	7033-3	7133-2	3997-1	3997-1	7038-1	7038-1	7116-1
8	2	Screw, set, nozzle	19969	19969	19969	15885	15885	15885	15885	15885	15885
9	1	Cover, rear	7032-1	7032-1	7032-1	3998-1	3995	3995-1	7037-1	7037-1	7037-2
10	1	Adpt,plate, rear cover	N/A	N/A	N/A	N/A	N/A	N/A	N/A	N/A	20150
11	4	Screw, rear cover	15886	15886	15886	15886	15886	15886	15886	15886	15886
12	1	Peepsight	10509	10509	10509	10509	10509	10509	13225	13225	13225
13	1	Spark Plug	23045	23045	23045	16927-1	16927-1	16927-1	23045	23045	23045
14	1	Flame Rod	17232-1	17232-1	17232-1	13312-6	13312-9	13312-9	N/A	N/A	N/A
14	1	Plug, protector, 0.5"	11456-1	11456-1	11456-1	11456-1	11456-1	11456-1	11456-1	11456-1	11456-1
15	1	Block, inlet, gas, NPT	3974-4	3974-4	3974-2	7001-1	7156-2	3973-3	3973-3	3973-2	3973-2
15	1	Block, inlet, gas, Rc	3974-3	3974-3	3974-1	7001-3	7156-1	3973-1	3973-1	3973-10	3973-10
16	2	Seal, O-ring	14777	14777	14777	17037	14778	14778	14778	14778	14778
17	4	Screw, inlet, gas	15887	15887	15887	15893	15893	15893	15893	15893	15893
18	1	Plate, orifice, natural gas	14191-1	14191-1	14191-8	14934-15	14188-28	14188-26	14188-1	14188-20	14188-3
18	1	Plate, orifice, propane	14191-20	14191-19	14191-23	14934-3	14188-14	14188-8	14188-1	14188-1	14188-1
18	1	Plate, orifice, butane	14191-18	14191-3	14191-22	14934-14	14188-29	14188-27	14188-6	14188-19	14188-19
19	1	Block, inlet, blower	3977-3	3977-3	3977-3	7108-4	7045-2	7045-2	N/A	N/A	N/A
20	4	Screw, inlet, air	20246	20246	20246	20270	16015	16015	15892	15892	15892
21	12	Washer, M8	15222 (13)	15222 (13)	15222 (13)	15222 (13)	15222 (13)	15222 (13)	15222	15222	15222 (16)
22	1	Plate, orifice, air	14188-23	14188-24	14188-25	20362-4	14802-11	14802-9	10039-1	10039-4	20152-3
23	1	Combustor, alloy	14887-6	14887-6	14887-6	20400	20716-1	20716-1	100236	101279	101278
24	1	Block and holder	N/A	N/A	N/A	N/A	N/A	N/A	100113	10013	101161
25	1	Combustor, SiC	20474	20474	20474	20463	20718	20718	N/A	N/A	N/A
26	1	Retaining ring, SiC	19970	19970	19970	20464	10003	10003	N/A	N/A	N/A
27	1	Gasket, SiC	19971	19971	19971	20465	10005	10005	N/A	N/A	N/A
28	1	Screw, FH	10001	10001	10001	10001	10001	10001	10001	10001	10001
29	1	Valve, BV-A, NPT	501239	501239	501200	501201	501201	501203	501203	501204	501204
29	1	Valve, BV-A, Rc	202081	202081	101248	101249	101249	101250	101250	101251	101251
30	1	Nipple, NPT	20901	20901	20905	18779	18779	18808	14704	14791	14791
30	1	Nipple, Rc	20903	20903	20906	20891	20891	20857	20823	20823	20823
31	1	Nipple, NPT	18731	18731	18761	18774	18774	18806	18806	15307	15307
31	1	Nipple, Rc	20902	20902	20904	20884	20884	20858	20858	20814	20814
32	1	Ratio-Regulator, NPT	11080	11080	19997	15939	15939	20312	20312	10315	10315
32	1	Ratio-Regulator, Rc	20900	20900	19998	19999	19999	20311	20311	19990	19990
33	1	Bushing, Ratio-reg	N/A	N/A	N/A	N/A	N/A	18503	18503	20305	20305
34	3	Line, loading, plastic tubing	34505 (ft.)	34505 (ft.)	34505 (ft.)	34505 (ft.)	34505 (ft.)	34505 (ft.)	34505 (ft.)	34505 (ft.)	34505 (ft.)
34	36	Line, Loading, S.S. hose	SC4 (in/wl)(2/30)	SC4 (in/wl)(2/30)	SC4 (in/wl)(2/30)	SC4 (in/wl)(2/30)	SC4 (in/wl)(2/30)	SC4 (in/wl)(2/30)	SC4 (in/wl)(2/30)	SC4 (in/wl)(2/30)	SC4 (in/wl)(2/30)
35	1	Fig.TB, Load line, plastic	14506 (2)	14506 (2)	14506 (2)	14506	14506	14506	14506	14506	14506
35	1	Fig, load line, SS hose	2484 (2)	2484 (2)	2484 (2)	2484	2484	2484	2484	2484	2484
36	1	Fig, load line, elb, plastic	N/A	N/A	N/A	14689	14689	14689	14689	14689	14689
37	1	Nip, fig, load line, 0.125"	18684	18684	18684	1494	1494	1494	1494	1494	1494
38	1	Tee, fig, 0.125	19160	19160	19160	19160	19160	19160	N/A	N/A	N/A
38	1	Cross, fig, 0.125	N/A	N/A	N/A	N/A	N/A	N/A	20668	20668	20668
39	1	Act, M7284-A-1004	12200	12200	12200	12200	12200	12200	12200	12200	12200
39	1	Act, M7284-C-1000	15273-4	15273-4	15273-4	15273-4	15273-4	15273-4	15273-4	15273-4	15273-4
39	1	Act, EMP 423-5	22755	22755	22755	22755	22755	22755	22755	22755	22755
39	1	Act, EMP 424-5	22735	22735	22735	22735	22735	22735	22735	22735	22735
39	1	ACT004A3B1A1AX, RH	*	*	*	*	*	*	*	*	*
39	1	ACT004A4B1A1AX, LH	-	-	-	-	-	-	-	-	-
40	1	Mtg. kit, HW	100099	100099	100099	100099	100099	100099	100099	100099	100099
40	1	Mtg. kit, rotary, right hand	100127	100127	100127	100127	100127	100127	100127	100127	100127

ThermAir Parts List (Continued)

Pos.	Qty.	Description	TA015	TA025	TA040	TA075	TA100	TA200	TA300	TA400	TA500
40	1	Mtg.kit,rotary,left hand	100128	100128	100128	100128	100128	100128	100128	100128	100128
41	1	Air switch,AA-A2-4-5-2-20	20475	20475	20475	20475	20475	20475	20475	20475	20475
41	1	Air switch,AA-A2-6-5-2-20	20440	20440	20440	20440	20440	20440	20440	20440	20440
41	1	Air switch,AA-A2-6-3-4-4	14641-1	14641-1	14641-1	14641-1	14641-1	14641-1	14641-1	N/A	N/A
41	1	Air switch,SMD,F,2-6	14494	14494	14494	14494	14494	14494	14494	14494	14494
41	1	Air switch,JD2-P,1-24"	16928-1	16928-1	16928-1	16928-1	16928-1	16928-1	16928-1	16928-1	16928-1
41	1	Air switch,JD2-P,1-10"	16928	16928	16928	16928	16928	16928	16928	16928	16928
42	1	Mtg.kit,Dungs,plastic	101146	101146	101146	101146	101146	101146	101146	101146	101146
42	1	Mtg.kit,JD2-P,plastic	100074	100074	100074	100074	100074	100074	100074	100074	100074
42	1	Mtg.kit,SMD,F,plastic	100075	100075	100075	100075	100075	100075	100075	100075	100075
42	1	Mtg.kit,Dungs,S.S.hose	101182	101182	101182	101182	101182	101182	101182	101182	101182
42	1	Mtg.kit,JD2-P,S.S.hose	101183	101183	101183	101183	101183	101183	101183	101183	101183
42	1	Mtg.kit,SMD,F,S.S.hose	101184	101184	101184	101184	101184	101184	101184	101184	101184
43	1	BLOWER	**	**	**	**	**	**	**	**	**
44	1	Grille,inlet stdblower	100347-1	100347-1	100347-1	100347-2	100347-2	100347-2	100347-2	100347-2	100347-2
44	1	Grille,inlet,3in. blower	100346	100346	100346	100346	100346	N/A	N/A	N/A	N/A
44	1	Filter,round	200758	200758	200758	200757	200757	200757	200756	200756	200754
44	1	Filter,square,20x20	N/A	N/A	N/A	101010	101010	101010	202731	202731	202731
44	1	Filter,silencer	15405	15405	15405	20505	20505	20505	15407	15407	15407
45	1	Mtr,115-208-230/1,TEFC	N/A	N/A	N/A	12033	12033	N/A	N/A	N/A	N/A
45	1	Mtr,208-230/460/3,std	N/A	N/A	N/A	13101	13101	N/A	N/A	N/A	N/A
45	1	Mtr,208-230/460/3,3 in.	N/A	N/A	N/A	N/A	14938	14938	20547	20548	16770
45	1	Mtr,575/3,TEFC	N/A	N/A	N/A	N/A	N/A	N/A	N/A	N/A	N/A
45	1	Mtr,115/1,TEFC	21631	21631	21631	N/A	25115	21475	21476	21477	21478
45	1	Mtr,208-230/1,TEFC	21727	21727	21727	N/A	N/A	N/A	N/A	N/A	N/A
45	1	Mtr,115/1,TENV	12995	12995	12995	N/A	N/A	N/A	N/A	N/A	N/A
45	1	Mtr,230/460/3,AUTO	N/A	N/A	N/A	20528	N/A	20530	N/A	N/A	N/A
45	1	Mtr,460/3,AUTO	N/A	N/A	N/A	N/A	N/A	N/A	N/A	N/A	N/A
45	1	Mtr,240/415/3,IEC 50Hz	20518	20518	20518	N/A	N/A	20522	20371	20392	20360
45	1	Mtr,230/1,IEC 50Hz	20554	20554	20554	20556	20556	N/A	N/A	N/A	N/A
45	1	Mtr,110/115/1,IEC 50Hz	21057	21057	21057	21059	N/A	N/A	N/A	N/A	N/A
45	1	Mtr,115-208/1,3in.TENV	N/A	N/A	N/A	21631	N/A	N/A	N/A	N/A	N/A
45	1	Mtr,208-230/460/3,TENV	21472	21472	21472	N/A	N/A	N/A	N/A	N/A	N/A
45	1	Mtr,575/3,TENV	21495	21495	21495	N/A	N/A	N/A	N/A	N/A	N/A
46	4	Screw,blower,slip fit	15881	15881	15881	N/A	15881	15881	N/A	N/A	N/A
47	4	Washer,M6	15625	15625	15625	15881	15881	15881	N/A	N/A	N/A
48	2	Plug,blower	20605	20605	20605	20605	20605	20605	20605	20605	20605
49	1	Fig.press,blower,0.125	N/A	N/A	N/A	N/A	N/A	N/A	N/A	N/A	N/A
50	1	Nut,M14, fig.press,blower	N/A	N/A	N/A	N/A	N/A	N/A	N/A	N/A	N/A

* ACT004A3B1A1AX
 ** BLOWER-PACKAGED1.1



Eclipse Combustion



Offered By:

Power Equipment Company
2011 Williamsburg Road
Richmond, Virginia 23231
Phone (804) 236-3800
Fax (804) 236-3882

www.peconet.com